



ARCHITECTURE

with sauce

Print out all parts and paint them in your favorite colors, before cutting them out.

Glue the page containing the building body onto a piece of thick paper.

Cut out all parts with scissors.

Use a ruler and a wooden stick to scratch the black dashed lines, this will make them fold easier.

Add all parts to the body step by step. The instructions on the next page will help you to do so. Afterwards, decorate your tower!

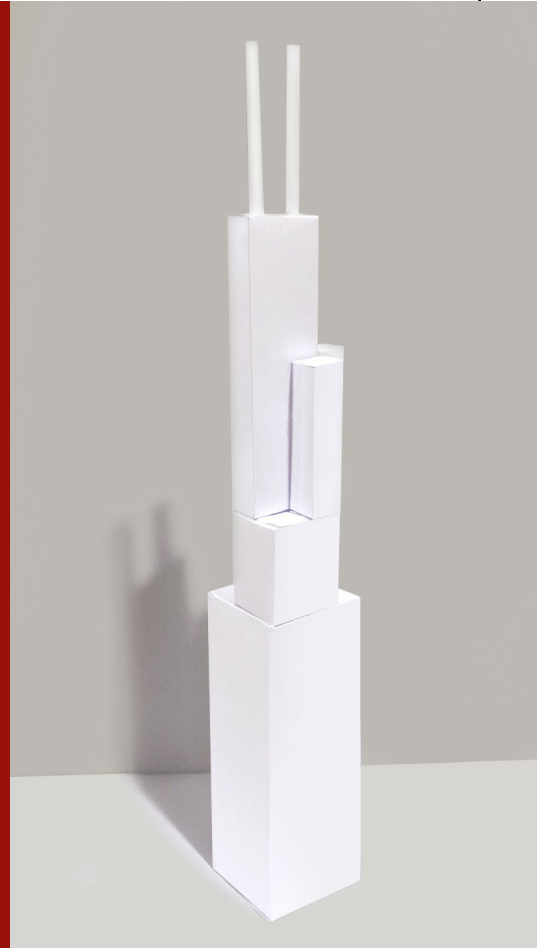

Willis Tower

CRAFTING MODEL

JUNIOR VERSION
SIMPLIFIED

The creation of this crafting set
was made possible by:



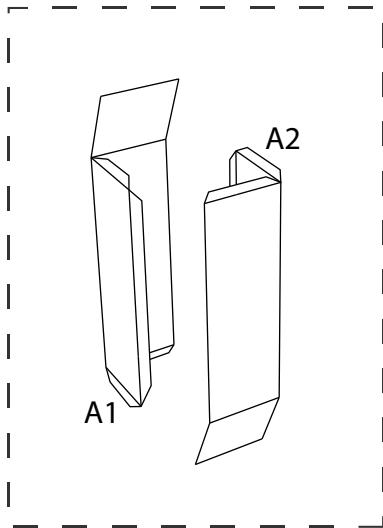

Fold the two pieces of the base and assemble them to form the base.

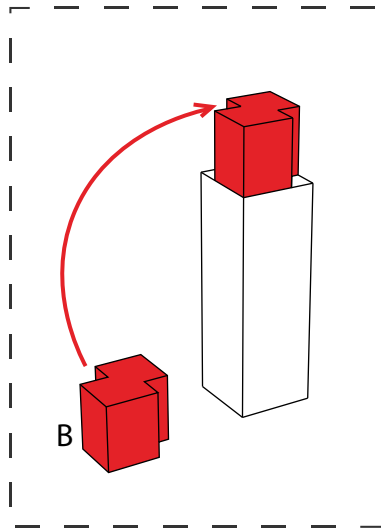

Fold the next part of the building body and stick it to the top of the base.

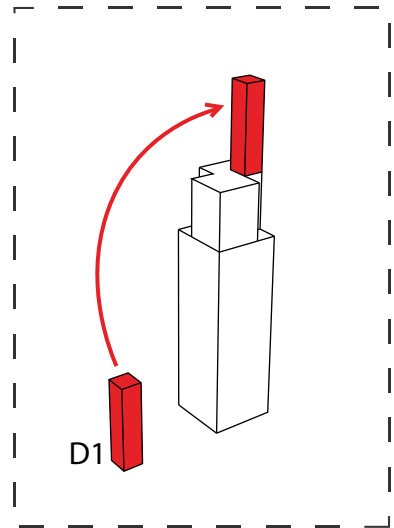

Fold the 1st block and attach it to the body of the building.

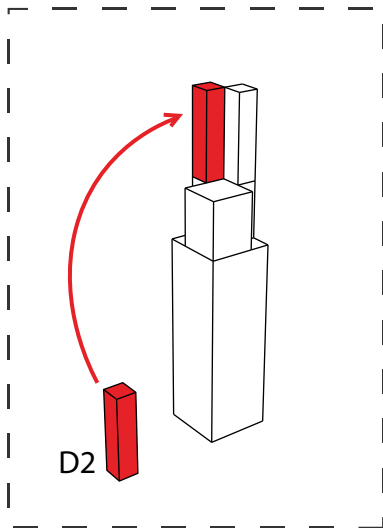

Fold the 2nd block and attach it also to the body of the building.

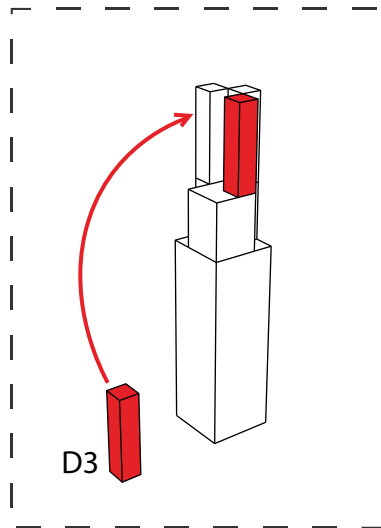

Fold the 3rd block and attach it to the body of the building as well.

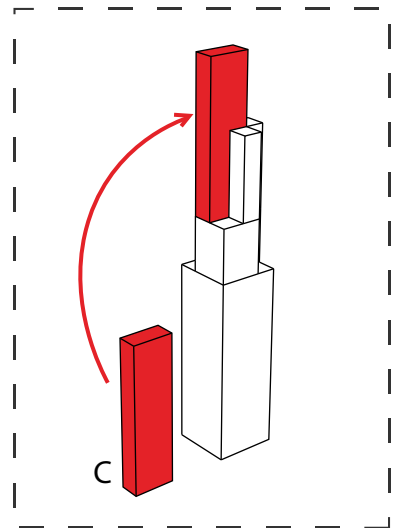

Fold the top section and attach it to the body of the building.

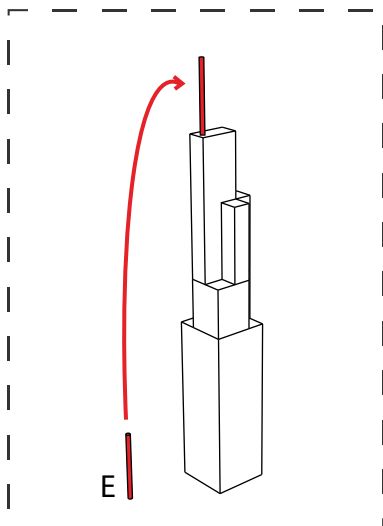

Roll the first antenna and mount it to the roof.

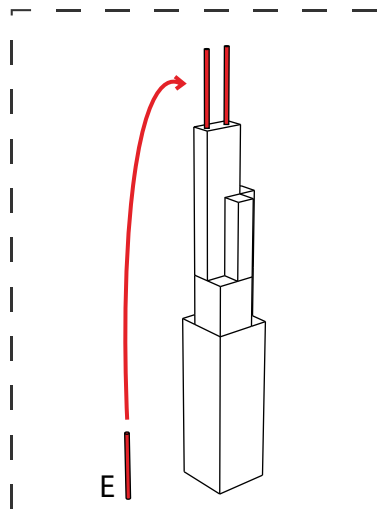

Finally, roll the second antenna and mount it to the roof as well.

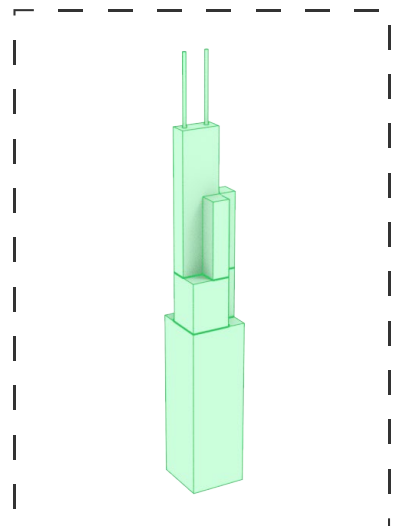

Congratulations, you did it!
To share your artwork with others,
please see the last page.

A1 (base)

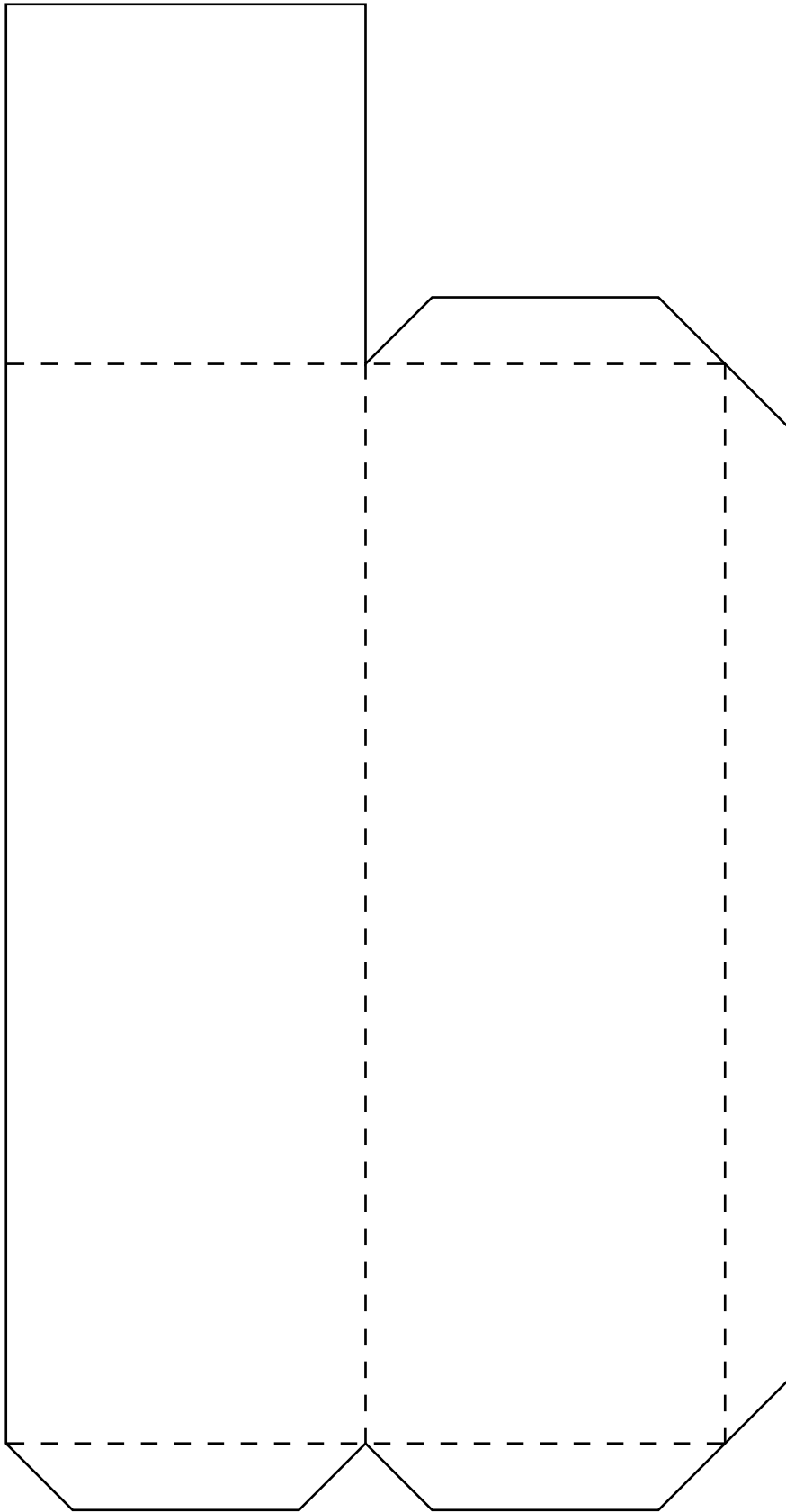

A2 (base)

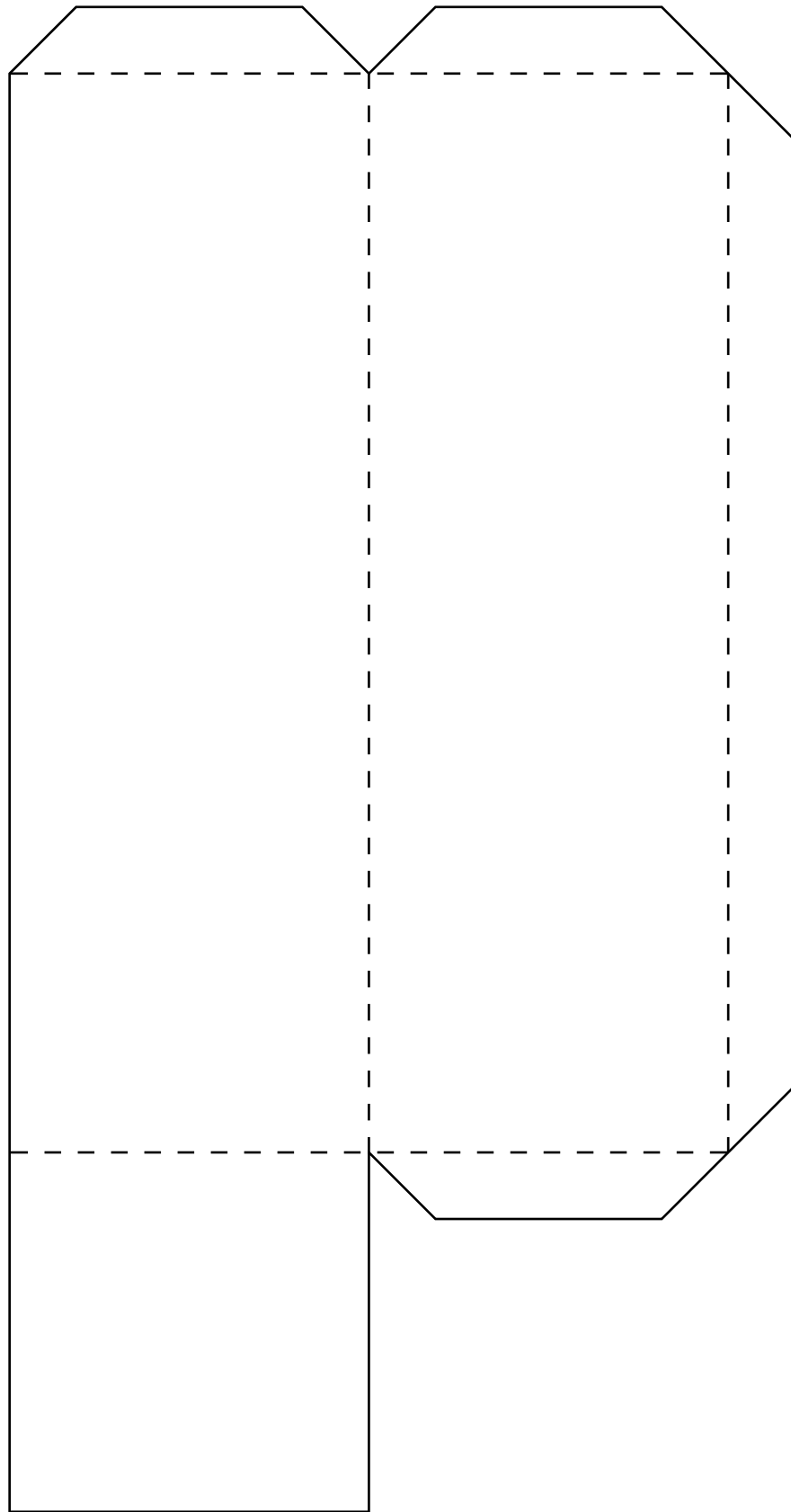

B (body part)

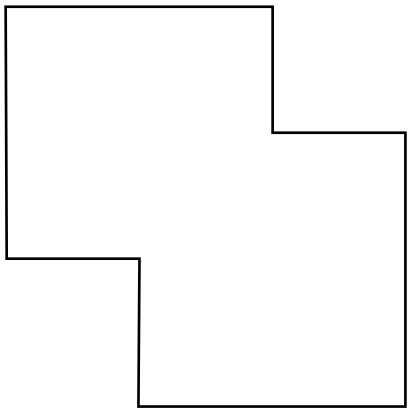
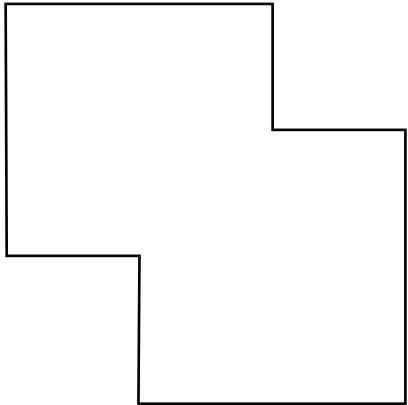
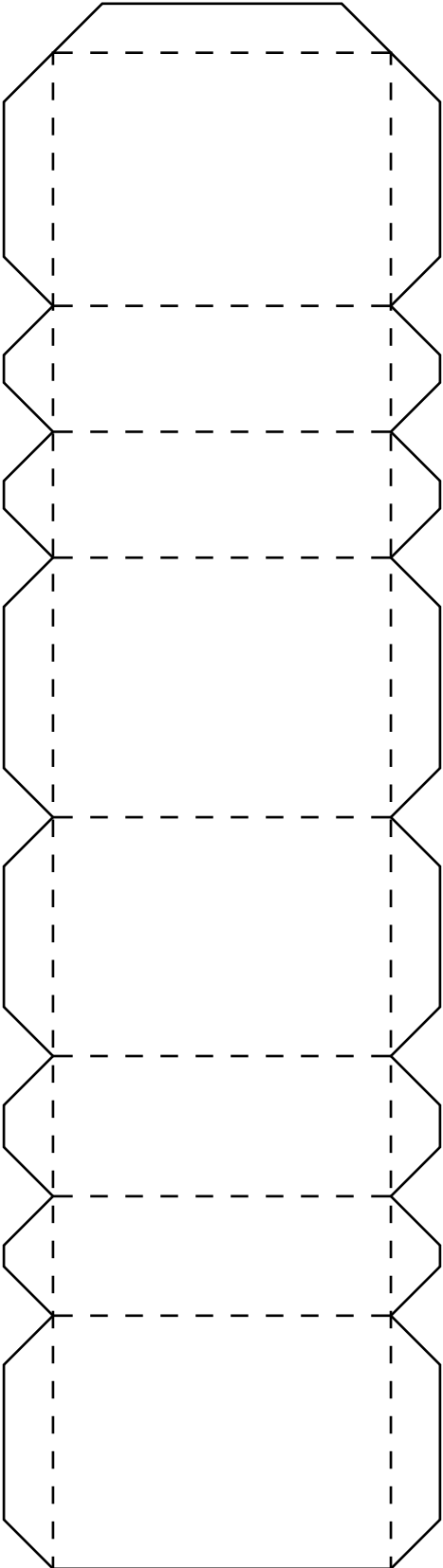

B (covers)

C (top section)

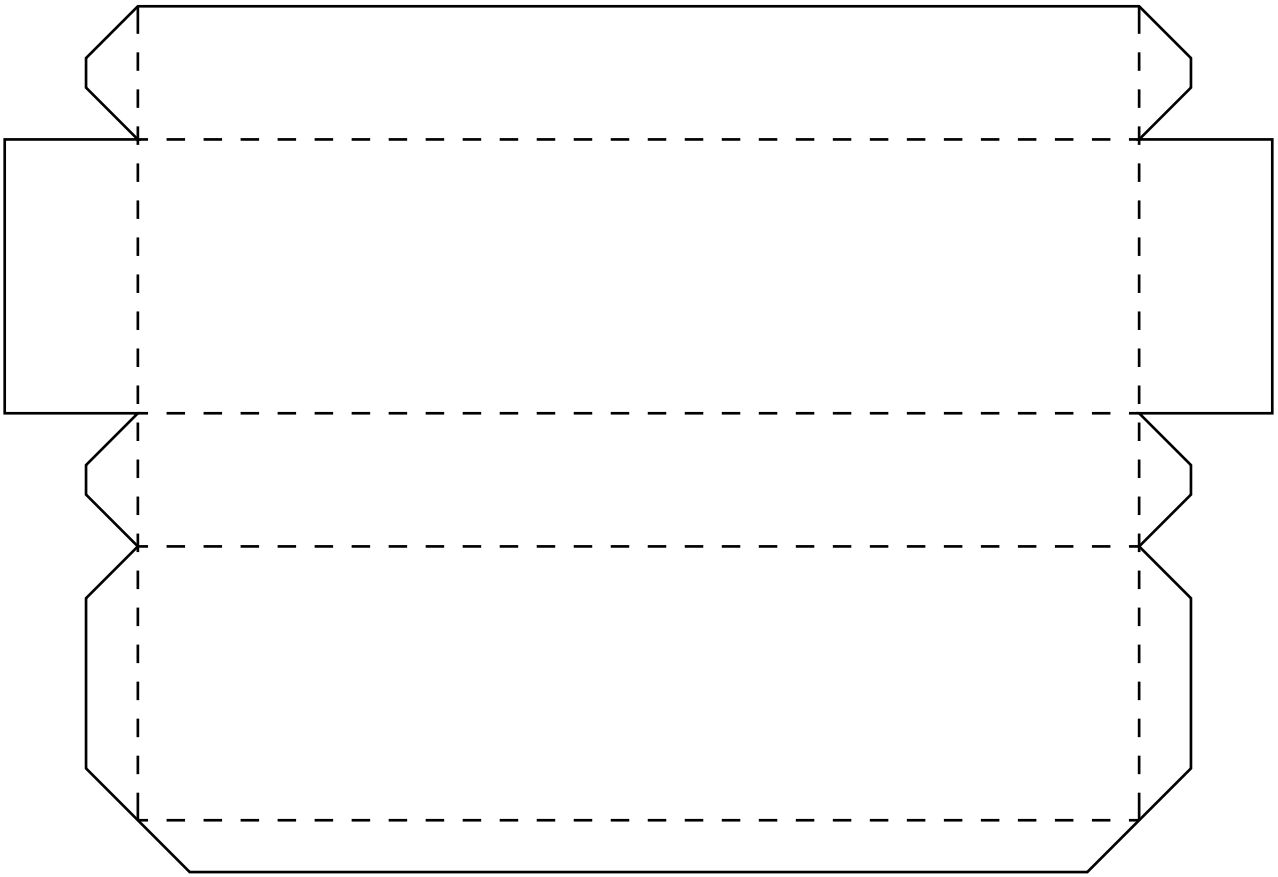

E (antenna)

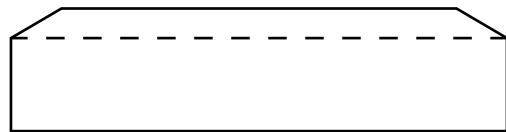
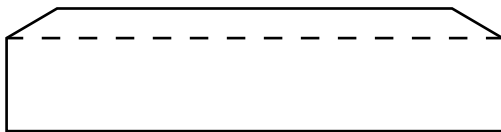

D (block)

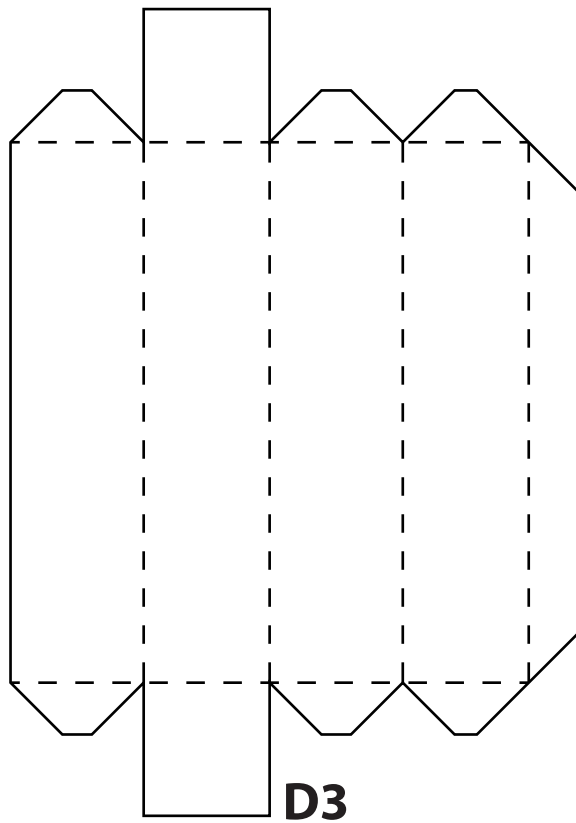
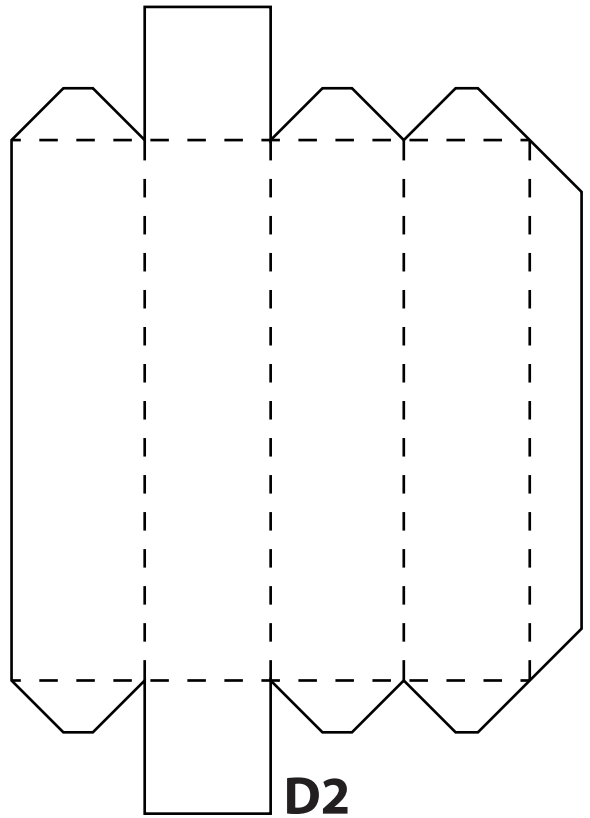
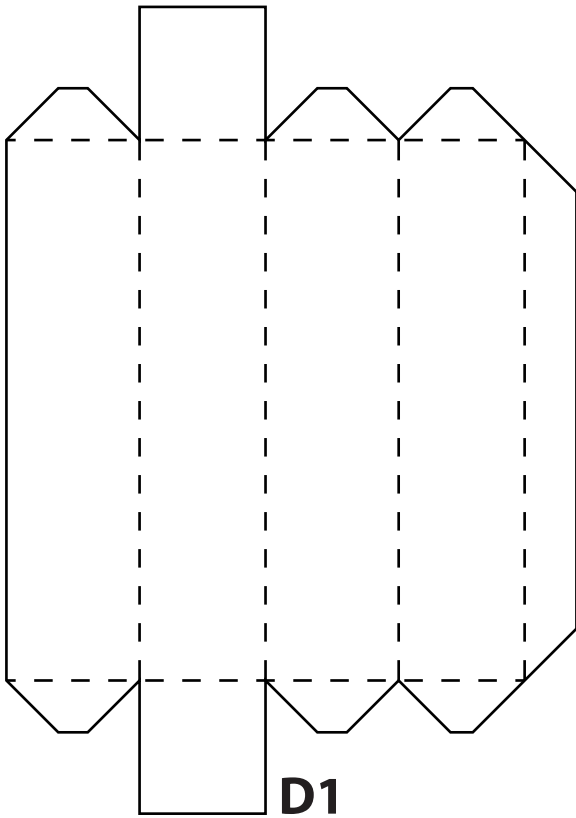



ARCHITECTURE

with sauce 

This tinker set has been provided by ARCHITECTURE with sauce, a project dedicated to offer crafting models.

Be sure to upload your building to the official gallery after you decorated it with colors or glitter: www.craftingmodels.com/upload/

You can share your artwork on social media using the tags #craftingmodel #chicago #theledge and #willistower.

Hungry for building more? You can download additional crafting sets directly online at www.craftingmodels.com

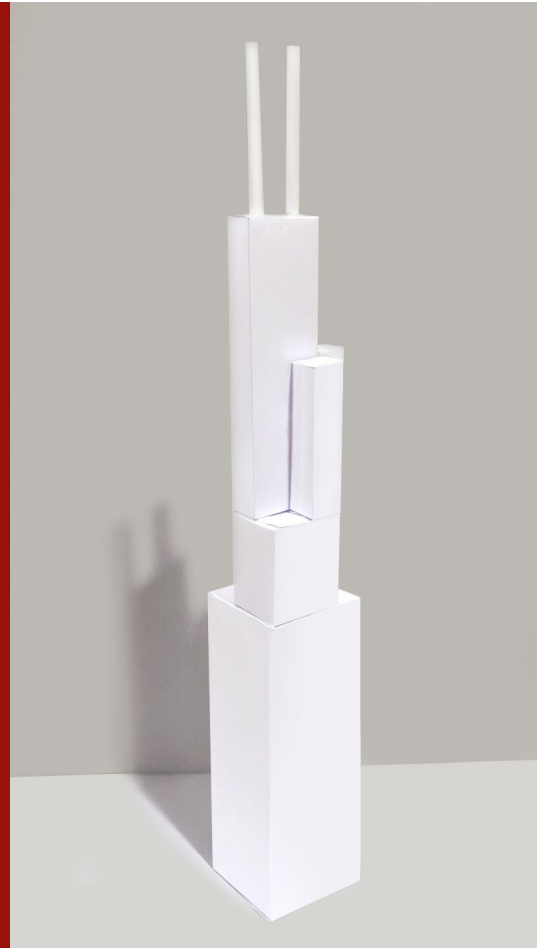

Willis Tower

CRAFTING MODEL 1:1000

difficulty: medium



Visit the world's largest database of skyscrapers and tall buildings on www.skydb.net. Be sure to also follow @skydb_net on social media.